

THIS OUTLINE APPLIES TO THE FOLLOWING MODELS:
M673L2/1800 RPM 60Hz 6kW 1Ø.....APPROX. WT. DRY..362 lbs. (164.2 kg)
M673L2/1500 RPM 50Hz 5.0kW 1Ø.....APPROX. WT. DRY..362 lbs. (164.2 kg)

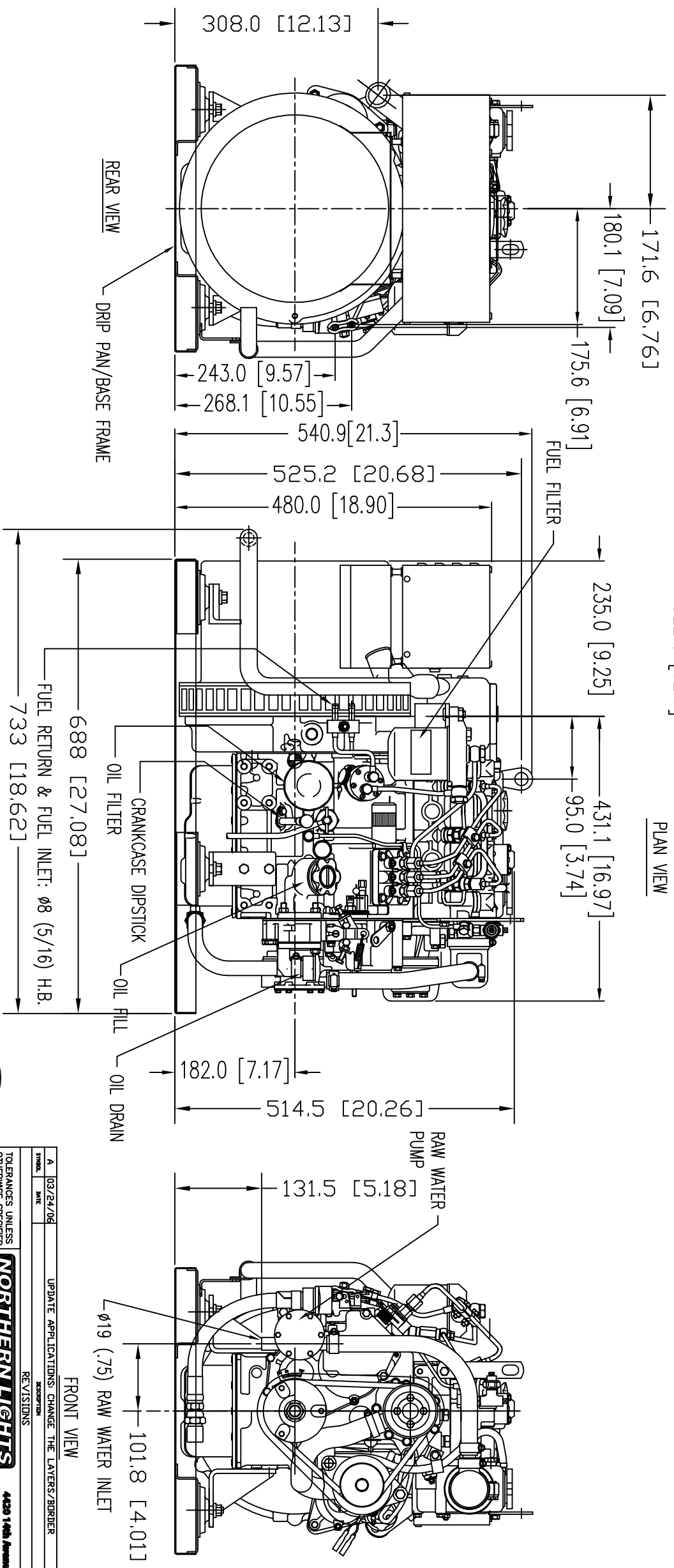

THE DIMENSIONS ON THIS DRAWING ARE SUBJECT TO CHANGE.
PLEASE CONTACT ADE TO BE SURE YOU HAVE THE MOST
CURRENT REVISION.

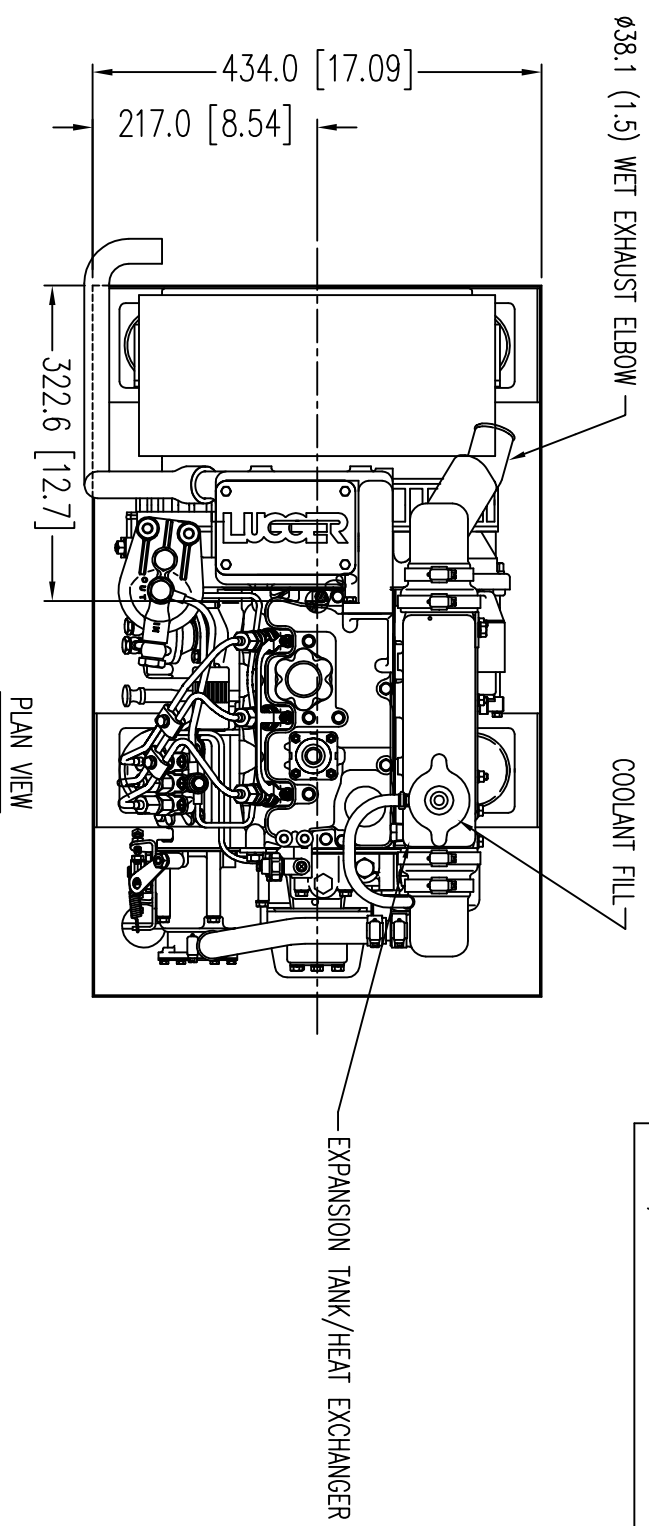

DATE	03/24/04	DESCRIPTION	UPDATE APPLICATIONS; CHANGE THE LAYERS/BORDER	BY	SLV
SYMBOL		REVISIONS		NO.	CHECKED
TOLERANCES UNLESS OTHERWISE SPECIFIED					
XXX	±.3				
.XXX	±.1				
ANGULAR	±1.0				
CAD					
REUSE ON CAD ONLY	CHECKED	DATE	01/15/05	TITLE	INSTALLATION DIMENSIONS
THIRD ANGLE PROJECTION	SCALE	1/5			
SHEETS	1	OF	1	P/W	
LIMITS OF MEASUREMENT	MUMI				
4430 14th Avenue N.W. Seattle, WA 98107 (206) 799-3999 www.northern-lights.com					
DWG. NO. C-5717 REV. A					