

The heritage continues.

For over 40 years, Northern Lights generators have been working for people who work on the water. From Bering Sea crabbers to bayou mud boats, push boats to high speed ferries; Northern Lights powers them all. The end result of this experience is the C2 Series powered by US EPA Tier II compliant, Lugger diesels. C2 sets combine high tech emission controls with the cast-iron reliability, simplicity, durability and product support you expect from a Northern Lights—all at a very affordable price.



Selection without compromise.

Underloaded and overloaded generators cause problems and waste money. With seven models, 20 to 150 kW, there is a Northern Lights commercial set that is right for your job. Mix and match these compatible sets for your best, single source, power solution.

Tough Lugger diesels.

Built for continuous duty, many Lugger powered sets have logged over 30,000 hours without a rebuild. Check the features and you will see why. Replaceable wet cylinder liners, liquid cooled turbos, cast-iron exhaust manifolds, plate oil coolers, cupronickel heat exchangers, gear driven seawater pumps. Rugged components built from the finest materials.

Simple to operate and maintain.

Hoses, gaskets and belts have been minimized. Control panels keep you in touch with your set's performance while safety shutdowns protect it. DC relays are used instead of printed circuit boards. Most service points are on a single side to simplify maintenance.

Electronic system profiler.

"ESP" is a window to your set's real time operating condition. The engine control unit that controls the electronic fuel injection on

40-150 kW

60 Hz / 1800 RPM

M65C2, M99C2 and M150C12 produces a stream of engine performance and diagnostic information that can be shown on an optional monitor.

Superior generator ends.

The sea is no place for a stand-by generator. All Northern Lights have low 95°/50° temperature rise ratings, Class H epoxy insulation and ±1.5% voltage regulation

Complete options list.

Each option is designed to integrate into a total power system custom built for your vessel. Consider a high power PTO that can supply up to 149 HP of hydraulic power at a touch of a button.

Total unit load testing.

Complete load testing is done with all accessories installed. Testing is just one of the quality controls that supports your decision to choose the very best commercial generator set for your workboat.

High resale value.

Northern Lights' quality reputation is a big plus when you sell your vessel. Buyers will know you cared enough to install the very best equipment.

The C-2 Commercial Series.

Premium commercial generator sets, at an affordable cost. Don't risk your livelihood to anything less.

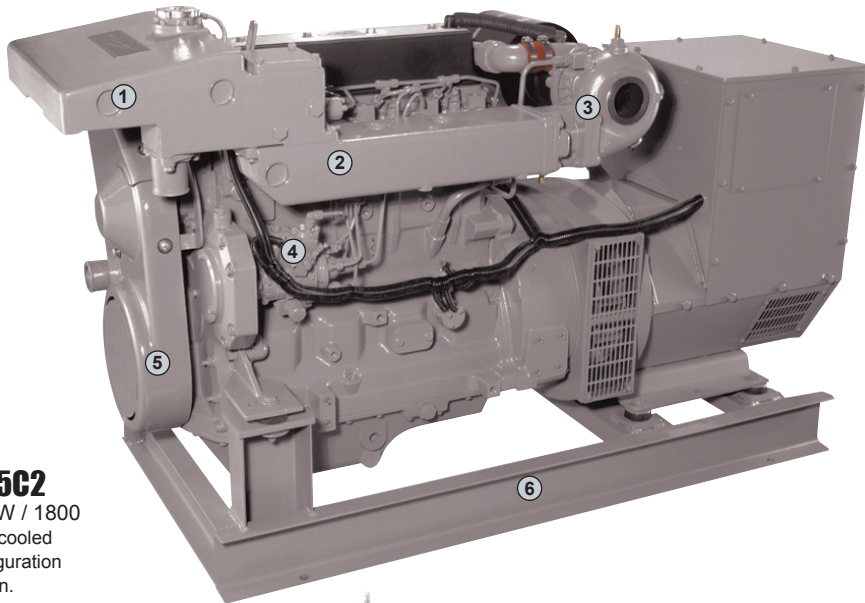

M55C2
55 kW / 1800
Keel cooled
configuration
shown.

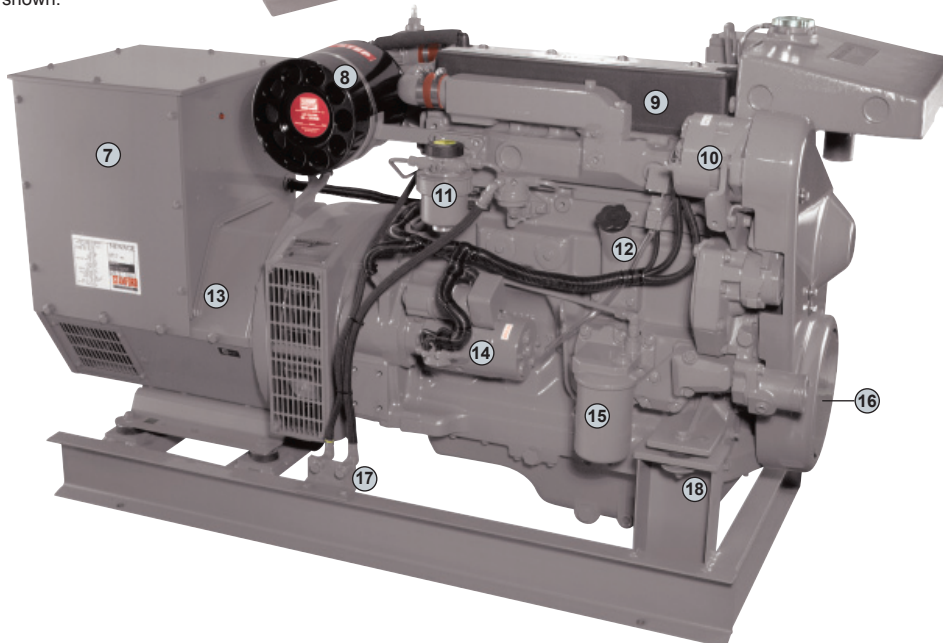

Features on your Northern Lights

1. Large, cast iron expansion tank (40 - 99 kW) or solid, fabricated expansion tank (150 kW).
2. Jacket-water cooled, cast iron exhaust manifold with two pass coolant flow.
3. Jacket-water cooled turbocharger for safety.
4. Rotary fuel injection pump: M40, M55, M65, M99. High pressure common rail: M150C12.
5. Molded belt guard protects the operator.
6. Welded steel base frame.
7. Junction box has AC terminal strip, automatic AC voltage regulator and DC system relays.
8. Air filter helps silence air intake noise.
9. Closed loop crankcase vent to keep oil vapors in the engine for a cleaner engine room.
10. 12 volt battery charging alternator.
11. Clamp style fuel filter(s) with vent and drain.
12. Service side lube oil fill.
13. Brushless, continuous duty generator end.
14. 12 volt starter placed high and dry.
15. Spin-on oil filter.
16. M40, M55, M65, M99: Taper nose crankshaft for high power PTO up to 149 HP.
17. Optional USCG fuel lines with fuel manifold.
18. Center bonded vibration isolation mounts.

C2 Commercial Series

Hard working features

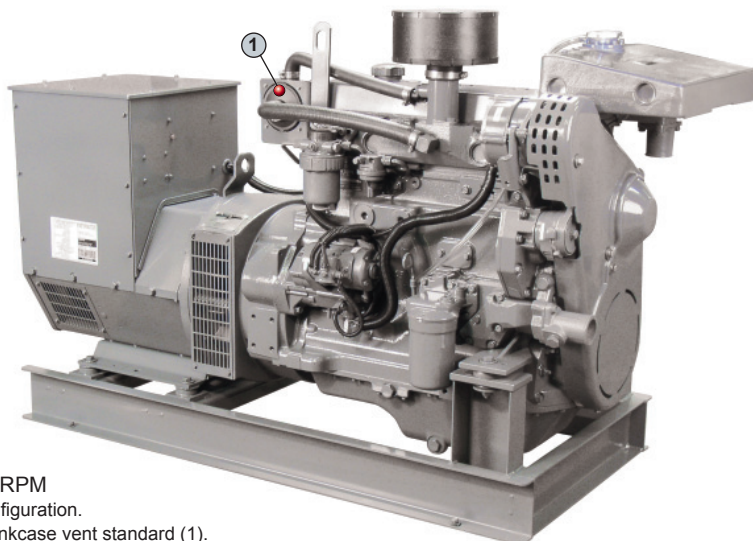

M40C2
40 kW / 1800 RPM
Keel cooled configuration.
Closed loop crankcase vent standard (1).

Model Specific Systems & Features

M40C2, M55C2:

- Mechanical rotary fuel injection pump with automatic timing advance for cleaner exhaust during start up and light load operation.

M65C2, M99C2:

- Electronically controlled rotary fuel injection pump for higher injection pressures, variable timing control and precise fuel metering. Higher power with lower emissions.
- Isochronous electronic governor for 0% AC frequency droop.
- Electronic System Profiler (ESP) see DC section below.

M150C12:

- High-pressure common rail (HPCR) for high output, improved fuel economy, better load response and low emissions. HPCR continuously supplies injectors with highly pressurized fuel for better fuel atomization. Injectors are electronically operated by an engine control unit giving nearly infinite control of fuel quantity, injection timing and multiple injection events per power cycle. Pilot injection reduces cold start smoke and noise.
- Isochronous electronic governor for 0% AC frequency droop.
- Electronic System Profiler (ESP) see DC section.

ENGINE BLOCK

- Lugger four or six cylinder, four cycle, in-line, liquid cooled, overhead valve, marine diesels based on heavy-duty industrial engine blocks.
- Balanced, forged crankshaft with induction hardened journals and rolled fillets for long life.
- Replaceable, wet cylinder liners for long life and low rebuild costs.
- Bimetallic valves have chrome stems and rotators.
- Replacable valve seats and guides.
- Three ring aluminum alloy pistons with Ni-Resist insert for the top ring. Keystone piston ring reduces carbon buildup under light loads.
- For smooth operation: four cylinders have two gear-driven, counter-rotating balancing shafts. Six cylinder have torsional crankshaft dampers.
- One poly-vee drive belt powers the alternator and jacket-water pump.

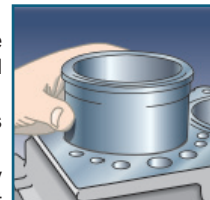

Fuel System

- Direct fuel injection systems
- Ring clamp fuel filter(s) have air bleed and drain.
- Diaphragm-type, mechanical fuel transfer pump with manual priming lever.
- See "Model Specifications" Box for more details.



Lubrication System

- Positive displacement gear-type oil pump.
- Full flow, spin-on oil filter.
- Oil spray cooling reduces piston crown temperature for longer life.
- Jacket-water, plate-type, full flow oil cooler reduces heat and lube oil breakdown.
- Large capacity oil pan.
- A closed loop crankcase vent to trap oil vapor and keep the vessel clean.

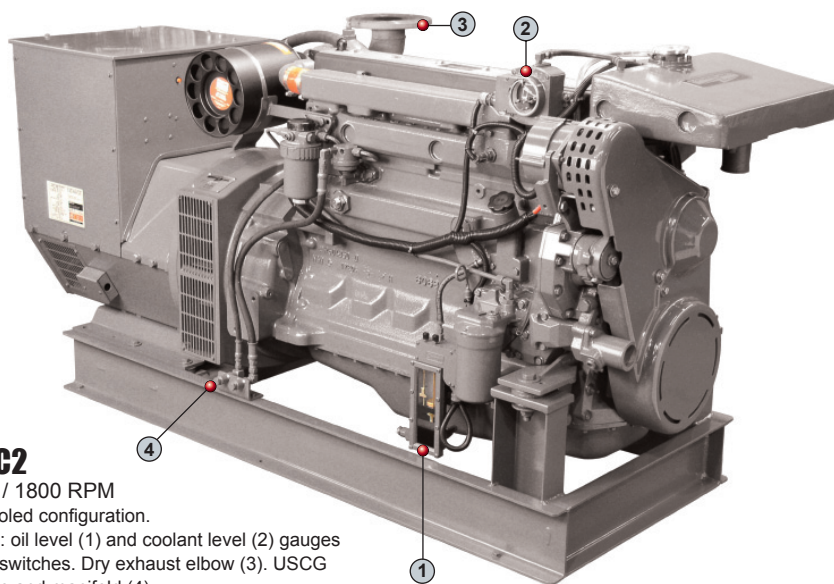

M99C2
99 kW / 1800 RPM
Keel cooled configuration.
Options: oil level (1) and coolant level (2) gauges - alarm switches. Dry exhaust elbow (3). USCG fuel lines and manifold (4).

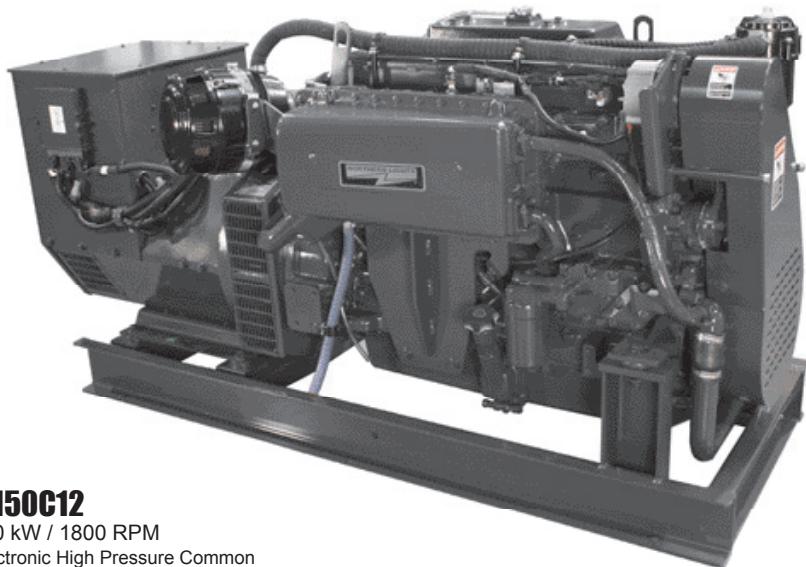

M150C12
150 kW / 1800 RPM
Electronic High Pressure Common Rail Fuel system. Keel Cooled.

Cooling System

M40C2 to M99C2:

- Cast iron expansion tank with brass filler (3).
- Two thermostats for quick warm-ups and safety.
- Cast-iron exhaust manifold (4) has two pass jacket-water flow for even temperature control.
- Keel cooled configuration is standard.
- Heat exchanger cooling option has: Cupro-nickel, tube type heat exchanger (5) with removable ends for easy cleaning. Gear driven, beltless, flexible impeller, sea water pump (6) is bronze and stainless steel.

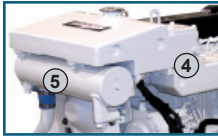

Air System

- Dry air filter silences intake noise.
- M40C2 is naturally aspirated. All others models have turbocharger with jacket water cooled turbine housings for safety.
- M150C12 has a jacket water aftercooler for improved combustion and output. No second keel cooler needed.

ESP and DC Electrical System

- M65C2, M99C2 and M150C12 have an Electronic System Profiler (ESP) which supplies a SAE J1939 data stream through a CANbus plug for optional engine monitor screen.
- Negative ground, 12 volt DC system has circuit breaker, starter motor and alternator with regulator.
- S-3C remote control panel with engine hour meter, coolant temperature gauge, oil pressure gauge, DC voltage meter, start-stop and shutdown bypass switches.
- Reliable, relay based DC system is easy to trouble shoot and repair. Up to 6 panels can be used up to 110 feet from set.
- Low oil pressure and high coolant temperature safety shutdown system.
- Prewired engine, panel have terminal strips.

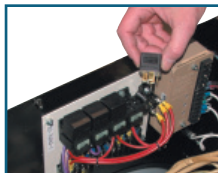

AC Generator

- Direct coupled, single bearing, 12 lead, reconnectable AC generator. Maintenance free brushless design.
- Generators meet or exceed class society standards with Class "H" insulation, accessible diodes, oversized ball bearings, marine grade shafts and conservative 95°/50° heat rise ratings.
- Engines and generators are torsionally matched for long life.
- Automatic voltage regulator; ±1.5% regulation over the entire range from no load to full load.
- M65C2, M99C2, M150C12: isochronous electronic governor for 0% AC frequency droop. M40C2 and M55C2 have mechanical governor for ±5% droop.

Special Equipment

- Welded steel base frame
- Belt guard
- Center bonded vibration isolation mounts
- Tough gray enamel paint
- Operator's and parts manuals

Northern Lights Commercial Series Options and Accessories

Your part of the marine industry has special power requirements. Here are just some of the options you can use to customize your Northern Lights set to match your vessel's needs and government requirements. These are not just add-ons. Each is engineered to be part of an integrated power system that works to enhance your comfort, safety and vessel operation.



Front crankshaft pulleys

Choose 3-AB groove or 4A groove pulleys to run your vessel's pumps, compressors and other equipment.



Double wall fuel lines

Give your fuel lines an extra layer for safety. May be required by USCG and other class societies and government agencies for your vessel.

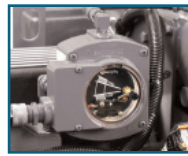

Pre-alarms/shutdowns

Coolant level, coolant flow, oil level and over-speed shutdowns. Pre-alarms warn you before any shutdowns occur.



Sight oil gauge/alarm

Check the oil level in your sump at one quick glance even when the set is running. Alarm warns you when oil level is low.



ESP monitoring panel

Your window to the operational condition of your set. Monitor all major engine functions on a read out screen mounted in a convenient location.

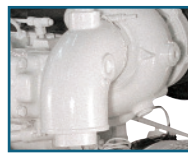

Exhaust components

Wet exhaust on keel cooled sets is available using a gear driven seawater pump and wet exhaust elbow. Wet mufflers and exhaust gas/water separators. Wet exhaust elbows. 3 and 4 inch dry exhaust elbows with flange. Dry exhaust flex couplings. Dry exhaust mufflers.



Electronic governors

M40C2 and M55C2: Protect your delicate electronics with precise engine speed and frequency control.



Permanent Magnetic Generators

The PMG is mounted onto the back of the standard generator end. PMG sends uncorrupted power to the automatic voltage regulator. This enhances

generator performance by making it more tolerant of nonlinear loads. Provides the 300% short circuit capability necessary for some USCG and society classifications. Voltage Regulation is ± 0.5% when selecting this option.

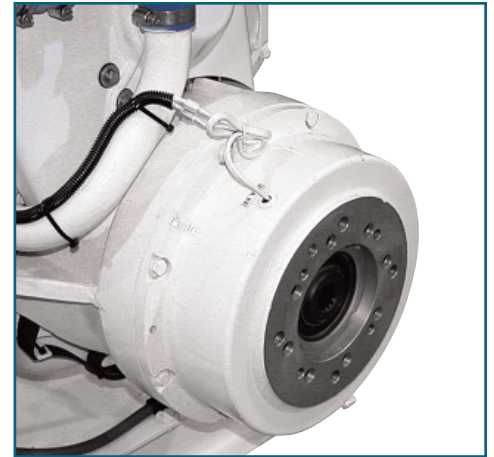

High HP front power take offs

At the touch of a button, the Northern Lights electric clutch PTO gives you instant power to run hydraulic bowthrusters, deck gear and winches. 12 or 24V clutch. B or C spline. Maximum PTO power at 1800 RPM: M40C2-60 HP, M55C2-90 HP, M65C2-102 HP, M99C2-149 HP, M150C12-118 HP.

24 Volt DC system

Need your set to have a 24 volt, standard ground DC system? No problem. Plus you get a choice of a 40A or 75A alternators.

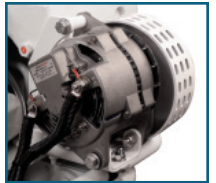

Control panels

How much control do you want? Choose from five control panels. Each is available in 12 or 24 volt. Monitor and control your generator using up to six panels up to 110 feet from the generator set.

S-1 Panel

Includes: Run light, start/stop switch and shutdown bypass/preheat switch.



S-1B Panel

Includes: Run light, engine hour meter, start/stop, and shutdown bypass preheat switch.



S-3B Panel

Includes: DC voltmeter, coolant temperature gauge, oil pressure gauge, engine hourmeter, start/stop, and shutdown bypass/preheat switch in a NEMA enclosure.



S3C Panel

Same features as S3B in a compact flush mount panel.



S-4 Panel

Includes: AC voltmeter, frequency meter, ammeter with phase selector switch, DC voltmeter, engine hour meter, engine oil pressure gauge, engine coolant temperature gauge and control switches. Available with flush mount panel or NEMA cabinet with hinged door.



C2-Series

General Specifications and Dimensions

AC Output ¹	M40C2	M55C2	M65C2	M99C2	M150C12
60 Hz, 1800 RPM¹ kW	40 kW	55 kW	65 kW	99 kW	150 kW
Voltage regulation	1.5%	1.5%	1.5%	1.5%	1.5%
Frequency droop control	±5%	±5%	Isochronous 0%	Isochronous 0%	Isochronous 0%
Phase and power factor	All Models: Three phase -0.8 power factor std. Opt.: Single phase -1.0 power factor except M99C2				
Generator full load temperature rise	All Models: 110°C temperature rise at 50°C ambient				
Lugger Diesel Engine Data					
Inline cylinders/aspiration/operating cycle	I-4 / Natural / 4	I-4 / Turbo / 4	I-4 / Turbo / 4	I-6 / Turbo / 4	I-6 / Turbo & Aftercooled / 4
Displacement - cid (liter)	276 (4.5)	276 (4.5)	276 (4.5)	414 (6.8)	414 (6.8)
Bore/stroke - inches (mm)	4.19/5 (106/127)	4.19/5 (106/127)	4.19/5 (106/127)	4.19/5 (106/127)	4.19/5 (106/127)
Oil capacity with filter - quarts (ltr)	14.3 (13.5)	14.3 (13.5)	14.3 (13.5)	20 (19)	20 (19)
HP @ 1800 RPM ² / Max front PTO HP @ 1800 rpm	62 / 60	99 / 90	102 / 102	150 / 149	consult factory
Cooling System (KC standard, HE optional)					
Heat rejection to jacket water -1800 rpm BTU min	2151	3267	4138	5336	9900
Freshwater pump capacity - 1800 rpm/gpm (lpm)	38 (144)	38 (144)	38 (144)	60 (227)	63.4 (240)
KC turbo tube length @ 85°F seawater dockside - ft	24	24	28	56	consult factory
KC steel skin cooler @ 85°F seawater dockside - sq ft	31	50	52	75	consult factory
KC keel cooler head diameter - in NPT	1.5	1.5	1.5	1.5	consult factory
KC keel cooler hose ID discharge/suction - in (mm)	2.25 (57)	2.25 (57)	2.25 (57)	2.25 (57)	consult factory
HE heat exchanger approx cooling capacity - gal (ltr)	5.5 (21)	5.5 (21)	5.5 (21)	6.5 (24.7)	5.5 (21)
HE seawater pump capacity - 1800 rpm/gpm(lpm)	24 (91)	24 (91)	24 (91)	24 (91)	40 (151)
HE max seawater pump suction head lift - in (m)	39 (1)	39 (1)	39 (1)	39 (1)	39 (1)
HE sea water pump inlet hose ID - in (mm)	1.25 (32)	1.25 (32)	1.25 (32)	1.25 (32)	2 (51)
HE min. seawater inlet/discharge thru-hull - in (mm)	1.25 (32)	1.25 (32)	1.25 (32)	1.25 (32)	2 (51)
DC Electrical (12V standard, 24V optional)					
DC starting voltage - standard (optional)	12 (24)	12 (24)	12 (24)	12 (24)	12 (24)
Min battery capacity - amp hr/12V CCA (24V CCA)	200 / 640 (570)	200 / 640 (570)	200 / 640 (570)	225 / 800 (570)	255/800 (570)
Starter rolling amps @ 0°C - 12VDC (24VDC)	780 (600)	780 (600)	780 (600)	920 (600)	920 (600)
12 Volt battery cable size up to 10 ft (3m)	"00"	"00"	"00"	"00"	"00"
Air					
Generator cooling air flow 1&3Ø - 1800 rpm cfm	595	595	955	1308	1308
Air consumption - 1800 rpm/cfm (m ³ /m)	127 (3.6)	201 (5.7)	226 (6.4)	352 (9.2)	545 (15.4)
Exhaust gas volume - 1800 rpm/cfm (m ³ /m)	357 (10.1)	512 (14.5)	618 (17.5)	851 (24.1)	1148 (32.5)
Exhaust gas temp - 1800 rpm/F° (C°)	1089° (587°)	959° (515°)	1040° (560°)	984° (529°)	709 (376)
Approx. heat radiated to air - 1800 rpm/BTU/min	328	451	533	812	1200
Max. exhaust back Pressure - inch H ₂ O (mm H ₂ O)	48 (1220)	30 (762)	30 (762)	30 (762)	30 (762)
Wet exhaust elbow OD- in (mm)	4 (100)	4 (100)	4 (100)	4 (100)	5 (127)
Dry exhaust elbow in (mm)	3 (75)	4 (100)	4 (100)	4 (100)	4 (100)
Fuel					
Fuel injection pump type and control	Rotary Mechanical	Rotary Mechanical	Rotary Electronic	Rotary Electronic	HPCR
Min suction & return line - in (mm)	3/8 (9.5)	3/8 (9.5)	3/8 (9.5)	3/8 (9.5)	3/8 (9.5)
Max fuel transfer pump suction lift - in (mm)	36 (914)	36 (914)	36 (914)	36 (914)	36 (914)
Max fuel flow to transfer pump at 1800 rpm - gph	29.9	29.9	21.5	23.5	40
Full load fuel returned to tank at 1800 rpm -gph	26.6	24.7	15.5	15.6	28
Specific fuel consumption max load 1800 rpm - lbs.hp.hr	0.389	0.369	0.378	0.377	0.376
Approx. fuel rate ³ at 1800 RPM full load - gph (lph) ³	3.29 (12.45)	5.14 (19.45)	6.01 (22.74)	7.92 (30)	11.8 (44.6)
Max Engine Operating Angle					
Continuous (with separate expansion tank)	All Models: Front Down: 0-5°, (0-10°). Rear Down: 0-12°. Left/Right Down: 0-5°, (0-23°)				
Intermittent (2 minutes)	All Models: Front/Rear Down: 0-30°. Left/Right Down: 0-30°				
Dimensions and Weight (Do not use for installation. Contact factory for installation drawings and info)					
Length - inches (mm)	64.3 in (1633 mm)	68.0 in (1727 mm)	70.9 in (1801 mm)	82.5 in (2094 mm)	82.7 in (2100 mm)
Width - inches (mm)	27.5 in (699 mm)	30.2 in (766 mm)	27.5 in (699 mm)	27.5 in (699 mm)	33.8 in (858 mm)
Height - inches (mm)	39.5 in (1004 mm)	37.6 in (955 mm)	38.6 in (981 mm)	39.3 in (599 mm)	41.6 in (1056 mm)
Weight - pounds (kilograms)	1812 lbs (822 kg)	1932 lbs (876 kg)	1941 lbs (882 kg)	2805 lbs (1274 kg)	3550 lbs (1612 kg)

NOTES:

1. Prime kW ratings for 3Ø at 0.8 power factor. Consult factory for deration factors.
 3. Based on prime kW rating at 1800. Fuel rate may vary depending on operating conditions.

2. Net flywheel hp rating for fully equipped engine at rated speed under SAE J816b.
 4. Contact factory representative or www.northern-lights.com for current information.

Dealer

4420 14th Ave. NW., Seattle WA 98107
 Tel: (206) 789-3880 • 1-800-762-0165 • Fax: (206) 782-5455

Information and dimensions subject to change without notice.

Northern Lights and Lugger are registered trademarks
 of Northern Lights, Inc.

© 2011 All rights reserved. Litho USA. L687 3/12



www.northern-lights.com