

Service Side (Shown with Optional Sound Enclosure)

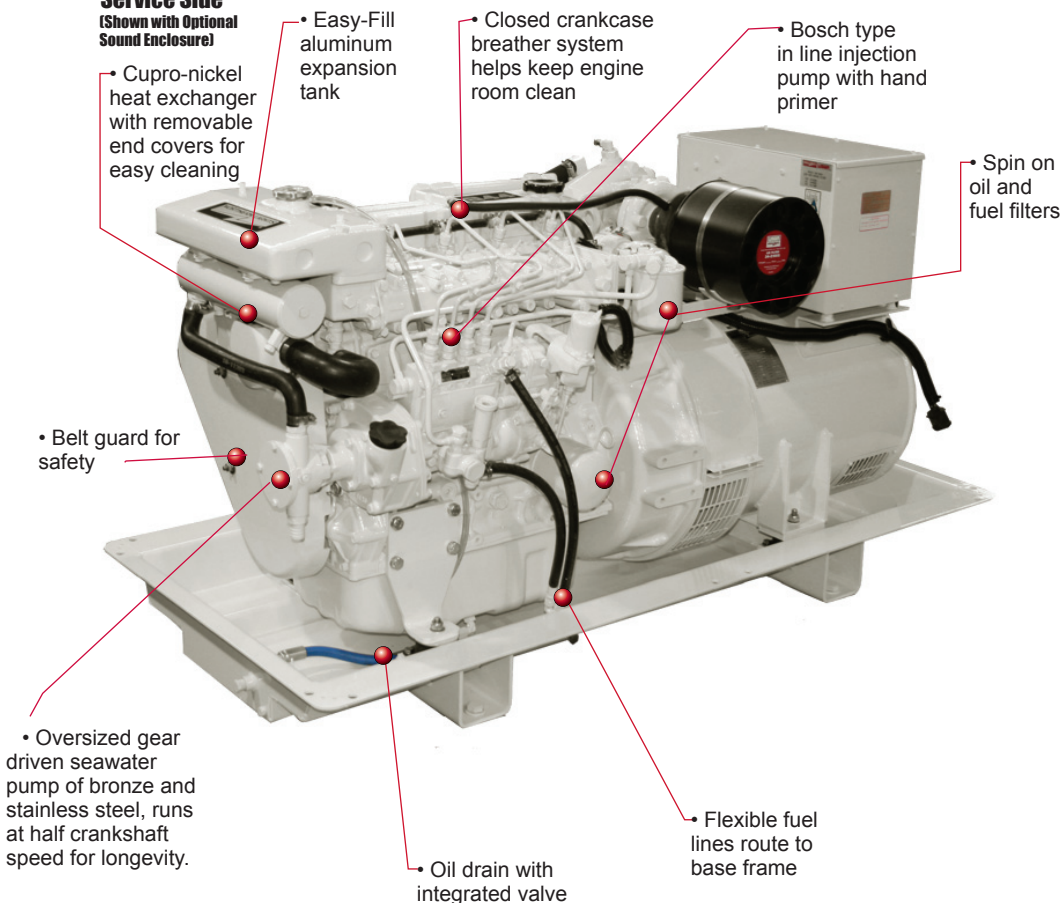

Non-Service Side

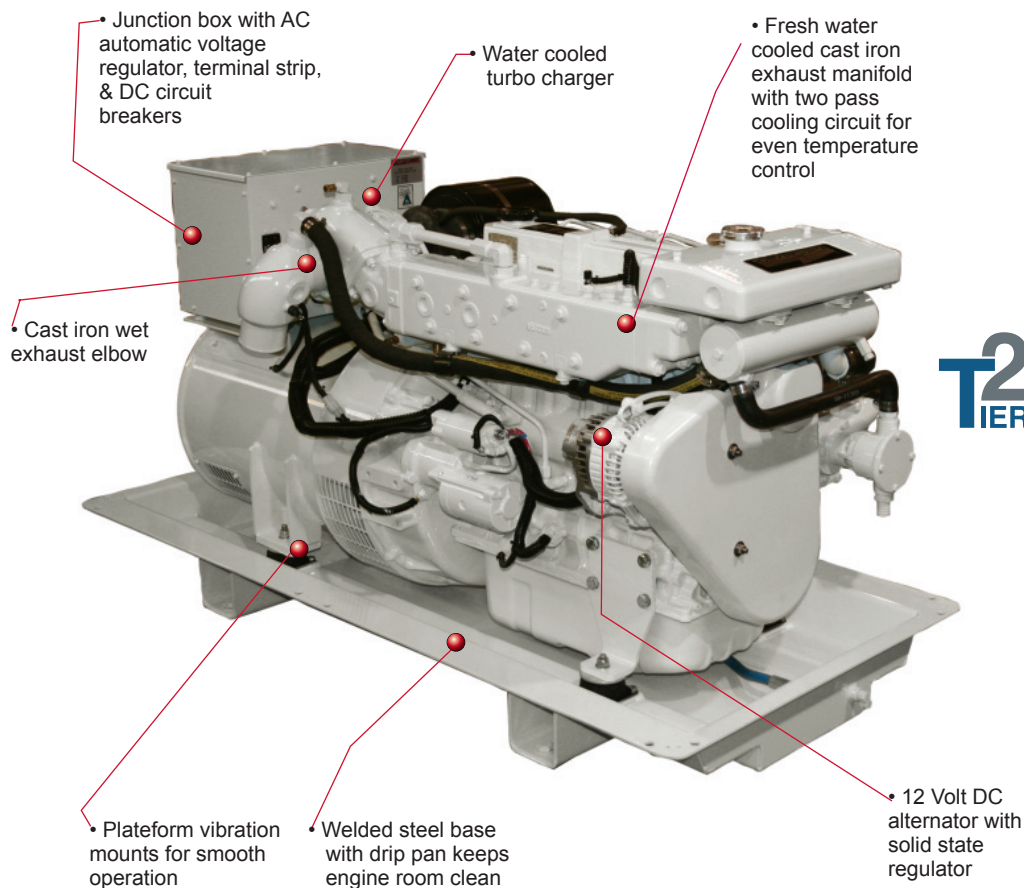

38 kW
60 Hz / 1800 RPM

32 kW
50 Hz / 1500 RPM

The Northern Lights M944T is the new industry leader in power density in the 32-40kW range.

Producing a conservatively-rated 38kW at 60 Hz (1800 RPM), or 32kW at 50 Hz (1500 RPM), the M944T is based on a heavy-duty industrial block engine and custom marinized for optimal marine performance.

The cast iron, two-pass exhaust manifold promotes even temperature control and is formed of sturdy cast iron. The cupro-nickel heat exchanger is built with removable end caps for easy cleaning. The gear driven seawater pump is self-contained with no unreliable belts. The turbo charger is fresh water cooled for safety.

All systems on the M944T are designed to provide reliable power production in a small space. At 38kW, the M944T is smaller than some competitors' 32. And because power is produced at a low 1800 RPM, engine wear is dramatically reduced.

Easily customizable, the M944T is an ideal set for increased power in the footprint of 25-33kW machine. Further maximizing engine room, is Northern Lights' exclusive new base frame and sound enclosure configuration (see table on back). Add custom panels, mufflers or even a front PTO to power your winches, bow thrusters or deck gear.

Clean and efficient, the M944T is US EPA Tier II certified, and is compliant with 2014 Tier III requirements. All the reliability, durability and simplicity that has made Northern Lights the industry leader for five decades are on display in the M944T.

AC Output¹	
38 kW	60 Hz, 1800 RPM, 1 Ph, 1.0 PF, 120-240 V/158A, 120V/316A
32 kW	50 Hz, 1500 RPM, 1 Ph, 1.0 PF, 220V/145A
Optional	Three Phase with 0.8 PF
Voltage regulation	±1%
Lugger L944T Engine	
Type	Vertical inline 4 cylinder diesel
Displacement	203 in ³ (3.33 ltr)
Bore	3.70 in (94 mm)
Stroke	4.72 in (120 mm)
Aspiration	Turbocharged
Fuel System	Bosch type inline injection pump
HP @ RPM	60.0/1800 50.0/1500

Approximate Fuel Usage	
1800 RPM @ full load ²	2.8 gph (9.8 lph)
1800 RPM @ half load ²	1.5 gph (5.3 lph)
1500 RPM @ full load ²	2.5 gph (9.5 lph)
1800 RPM @ half load ²	1.3 gph (4.9 lph)
Installation Data & Weight	
Wet exhaust elbow	3 in (76 mm) OD
Raw water inlet	3/4 in (19 mm) OD
Fuel inlet and return	1/4 inch NPT
Approximate dry weight	1417 lbs (643 kg)

- Based on SAE J1995 and ISO 3046.
- Actual fuel consumption will vary depending on operating conditions.

M944T Dimensional Drawing

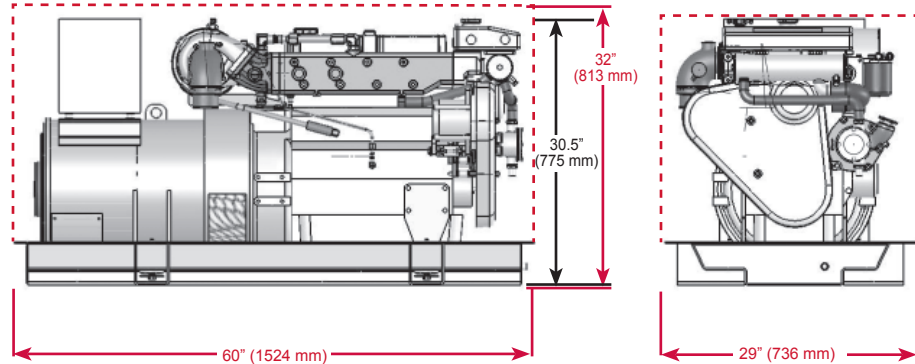

M944T Overall Dimensions L x W x H: 60 x 29 x 30.5 inch (1524 x 736 x 775 mm)
Overall Dimensions with sound enclosure L x W x H: 60 x 29 x 32 inch (1524 x 736 x 813 mm)
 Dimensions given in inches (mm). Dimensions subject to change without notice.
 Contact dealer or visit www.northern-lights.com for most current installation drawings.

M944T Features and Benefits

Engine Block

- Lugger, four cycle, 4 cylinder, liquid cooled, overhead valve marine diesel based on a heavy-duty engine block.
- Crankshaft is induction hardened, forged carbon steel; stronger than cast iron.
- Helical cut and ground, carbon steel timing gears reduce noise.
- Cross flow head for efficient breathing.

Cooling System

- Heat exchanged freshwater cooling system. Features: Easy to clean, tube-type, cupro-nickel heat exchanger. Impeller seawater pump forged of bronze and stainless steel is fully accessible. Gear driven pump without worrisome belts.
- Large, easy fill expansion tank.
- Cast iron exhaust manifold is freshwater cooled for safety. No hot, dry risers.
- Zinc anode electrolysis protection.

Fuel System

- Direct Injection with glow plugs.
- Bosch-type in-line injection pump with 5% mechanical governor for close AC output frequency control.
- Pintle type injectors.
- Mechanical fuel lift pump with hand primer.
- Large spin-on fuel filter.
- Flexible fuel lines routed to base.
- Stop solenoid controls fuel rack, not throttle, for fast engine shutdowns.



Lubrication System

- Full flow, spin-on oil filter with bypass.
- 10.5 qt (10 ltr) center well oil pan.
- Lube oil drain for quick oil changes.

Intake and Exhaust

- Fully compliant with all current US EPA emission requirements.
- Liquid-cooled turbocharger.
- Replaceable air cleaner/silencer and cast intake manifold reduces intake noise.
- Cast iron, wet exhaust elbow for safety.

DC Electrical System

- DC system uses reliable relays instead of unrepairable printed circuit boards.
- 12 volt starter and battery charging alternator with regulator.
- Standard panel: Remote mount S-3C has hour meter, oil pressure gauge, coolant temperature gauge, DC voltmeter, stop-start switch and preheat switch.
- 20 ft (6 m) plug-in panel harness lets you monitor your set from the bridge.
- Expandable to six panels, 110 ft from set.
- Low oil pressure, high coolant temp and high exhaust temp shutdowns are standard.



AC Generator

- Northern Lights, direct coupled, brushless AC generator is maintenance free.
- 50 or 60 hz output standard. 12 wire reconnectable generator standard. Conservative 95°F/50°C ambient heat rise.
- Generator features: high quality, Class "H" insulation, accessible diodes, oversized bearing and junction box for AC wiring.
- Automatic Voltage Regulator (AVR) is powered by dedicated AC winding for true 300% short circuit capability. AVR gives quick +/-1% RMS no load to full load voltage regulation. AVR has circuit breaker protection.

• Contact factory for information on classification standards.

The M944T is the first Northern Lights to utilize our revolutionary new frame design.

The sound enclosure shares a base frame with the generator set, creating a compact power and sound attenuation package that reduces noise and vibration while maximizing engine room space. This design allows for the easy installation of an additional set of vibration mounts for a smoother, quieter package with only a minimal increase in height.



- Stainless steel paddle latches on top, front and service side provide easy access to service points.
- Interior latches on non-service sides improve aesthetics.
- Three layers of firm and flexible sound dampening materials absorb low-, mid- and high-frequency noise.
- Protective film coating ensures safety and longevity.
- Fuel and oil drains outside of the sound enclosure for easy connection.
- Front exhaust exit option.
- Tough, white, powder-coat finish.

Dealer

4420 14th Ave. NW., Seattle WA 98107
 Tel: 206-789-3880 • 1-800-762-0165 • Fax: 206-782-5455
 Information and dimensions subject to change without notice.
 Northern Lights and Lugger are registered trademarks
 of Northern Lights, Inc.
 © 2011 All rights reserved. Litho USA. L732 4/11



www.northern-lights.com