

Commercial Series

20 kW

60 Hz / 1800 RPM

When continuous power is a necessity.

20 kW sets go into commercial vessels that need continuous AC power to operate. Without power the work doesn't get done. Unfortunately most sets this size have small displacement, light duty diesels that can't stand up to heavy use. Some even need turbochargers to compensate for their small displacement.

The M20CRW3 is different. Powered by a naturally aspirated, four cylinder, 2.2 liter (135 cid) Luger diesel, this set has the low end torque needed to start big electric motors without breaking a sweat.

You choose heat exchanger or keel cooling. The marinization is designed to reduce belts, hoses, gaskets and other trouble spots. The components are stoutly built from the best materials: cast-iron, cupro-nickel, stainless steel and bronze.

Strong and clean, the Luger meets US EPA Tier III emission standards to protect the environment you depend on for your living.



An engineer's dream, the set is simple to operate and maintain. The DC electrical system uses reliable relays instead of delicate printed circuit boards. If a failure should occur, you can simply plug in an inexpensive relay. Relay DC logic lets you have multiple control panels up to 110 feet from the set. All service points are on one side within easy reach.

Need hydraulic power? Add an optional electric clutch front PTO. At the touch of a button you have up to 30 HP at 1800 rpm to run your hydraulic equipment.

Got a big job hauling, towing, pushing, patrolling or fishing? Need a simple, reliable, durable, affordable set? You've found it. Let your dealer put a M20CRW3 to work for you before your next trip out.

Featuring the W-Series generator

The W-Series generator end used on this model features an auxiliary stator winding that supplies separate and stable power to the Automatic Voltage Regulator (AVR). The results are impressive:

- Classification society compliance.
- Real 300% short circuit capability.
- Improved AC circuit breaker performance.
- Quick ±1% RMS no load to full load voltage regulation
- 12 leads. Reconnectable 1 or 3 phase.

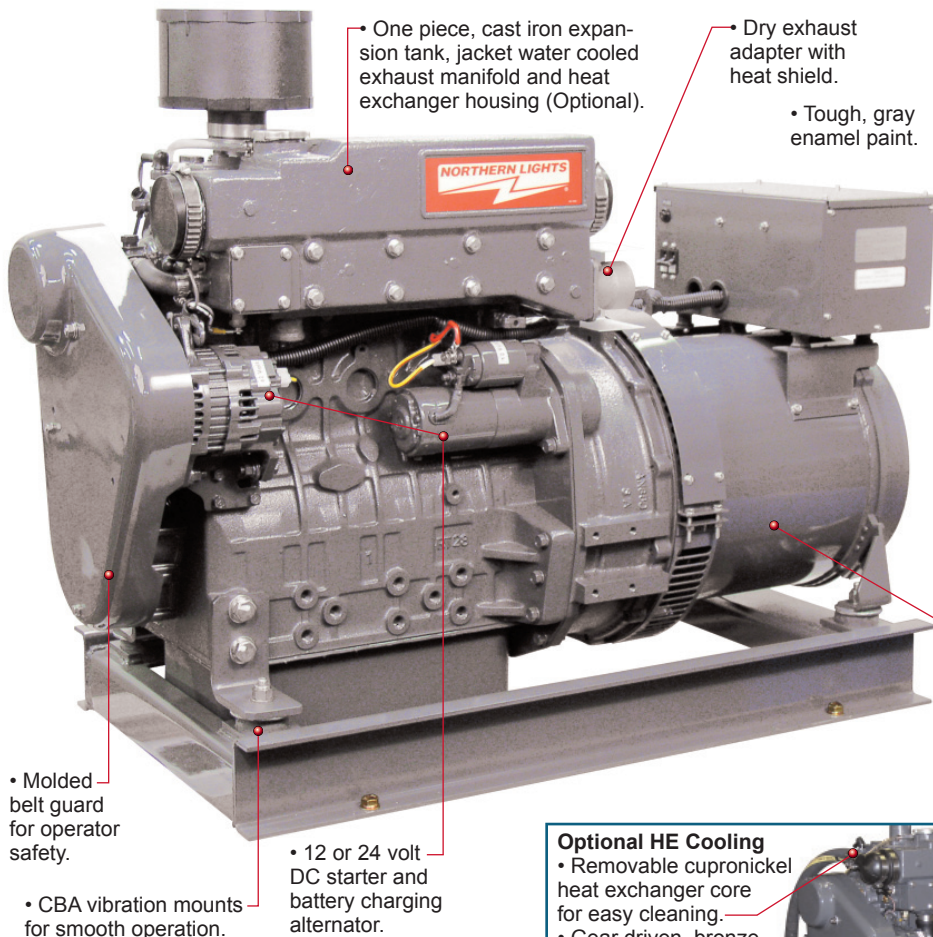
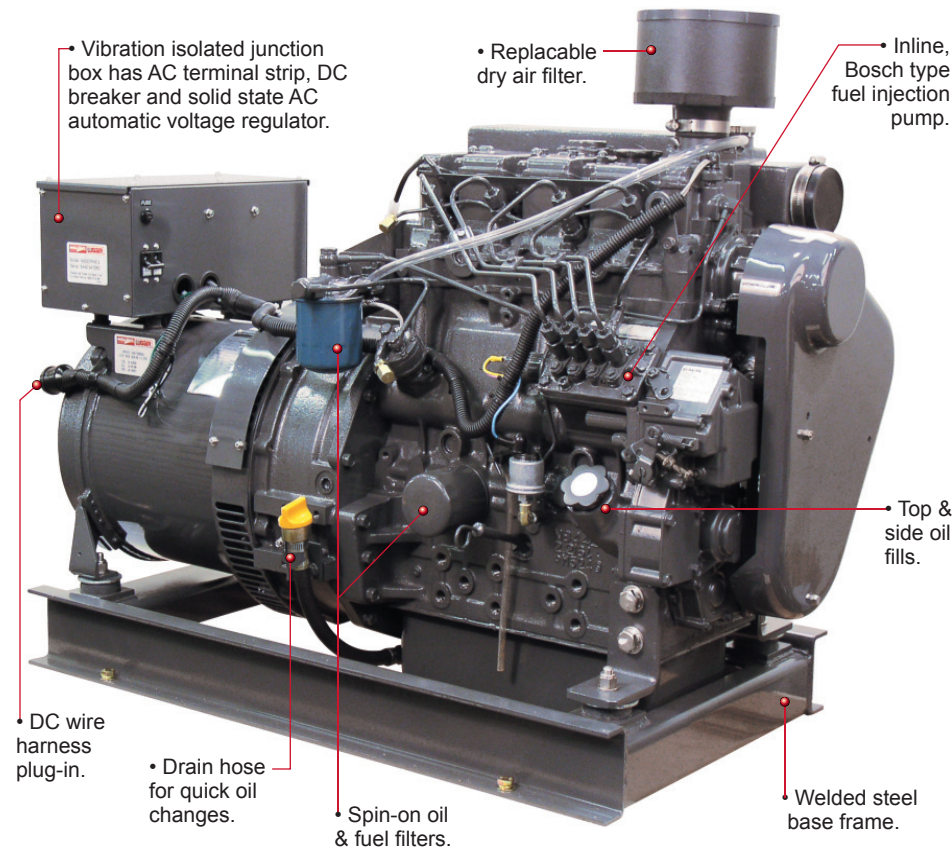

Optional HE Cooling

- Removable cupronickel heat exchanger core for easy cleaning.
- Gear driven, bronze and stainless-steel sea water pump. Mechanical seals. No drive belt.

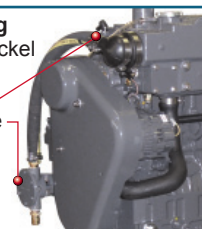

AC Output ¹	
20 kW	60 Hz, 1800 RPM
Amperage	120-240V / 83 A, 120V / 166 A
Phase	Three /0.8 PF or Single /1.0 PF
Voltage regulation	±1%

Lugger L844L2 Engine	
Type	Vertical inline 4 cylinder diesel
Displacement	135 in ³ (2.2 ltr)
Bore/Stroke	3.30/3.90 in (84/100 mm)
HP @ RPM	32/1800
Approx. fuel use	
1800 RPM @ full load ²	1.7 gph (6.5 lph)
1800 RPM @ half load ²	1.0 gph (3.9 lph)

Installation Data & Weight	
Wet exhaust elbow	2 inch OD
Dry exhaust outlet	1 1/2 inch NPT
HE raw water inlet	3/4 inch (19 mm) OD
KC coolant inlet / outlet	1 1/4 inch OD
Keel Cooler	6 ft turbo tube /12 ft plain tube
Fuel inlet	5/16 inch JIC male
Fuel return	1/4 inch JIC male
Approximate dry weight	919 lbs (416 kg)

1. Based on SAE J1995 and ISO 3046. 2. Actual fuel consumption will vary depending on operating conditions.

M20CRW3 Dimensional Drawing

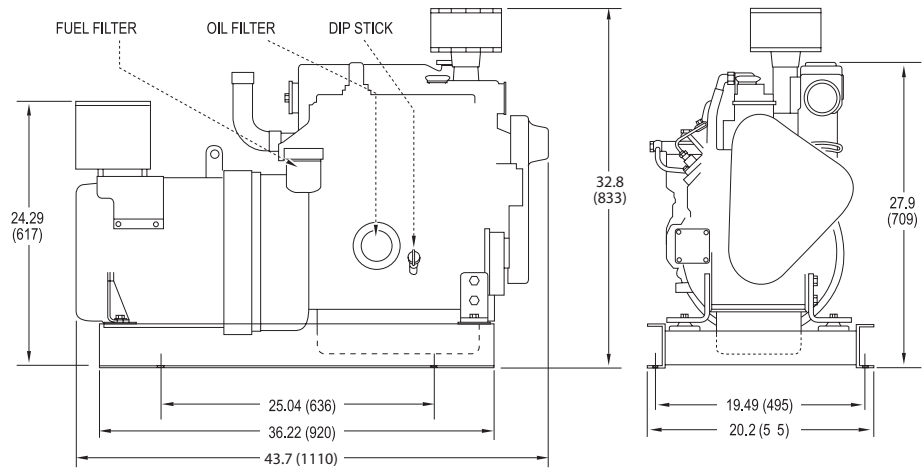

*Consult factory for straight 120 volt

M20CRW3 overall dimensions L x W x H: 43.7 x 20.5 x 32.8 inch (1110 x 523 x 833 mm)

Dimensions given in inches (mm). Dimensions subject to change without notice. Contact dealer or visit www.northern-lights.com for most current installation drawings.

Features and Benefits

Engine Block

- Four cycle, 4 cylinder, liquid cooled, naturally aspirated, overhead valve diesel.
- Swirl combustion chambers improve fuel efficiency and reduce smoke.
- Glow plugs for quick cold starting.

Cooling System

- Jacket-water cooling system in heat exchanger or keel cooled configuration.
- One-piece heat exchanger housing, expansion tank and liquid cooled exhaust manifold. Fewer troublesome hoses and gaskets. Cast iron to resist corrosion and electrolysis.
- Keel cooling configuration is standard
- Heat exchanger cooling is optional. Cupronickel, tube-type heat exchanger element can be removed for easy cleaning. Easily accessible, rubber impeller seawater pump of bronze and stainless steel is gear driven; no pump drive belts to fail. Cast-iron wet exhaust elbow is included.

Intake and Exhaust

- Meets US EPA Tier III emission requirements for a cleaner environment.
- Disposable dry air cleaner.
- 1 1/2 inch NPT exhaust outlet.



Lubrication System

- Full flow, spin-on oil filter with bypass.
- 8.6 qt. (8.2 ltr) oil capacity for better lubrication. 200 hr oil change intervals.
- Oil drain for quick, clean oil changes.
- Closed crankcase vent system keeps oil vapor inside engine for clean engine room.

Fuel System

- Fuel system is self-venting.
- Injection pump with 5% mechanical governor for close AC frequency control.
- Pintle injectors with replaceable tips.
- Mechanical lift pump with hand primer. No electric pump to fail.
- Large spin-on fuel filter.
- Stop solenoid controls the fuel rack, not throttle, to eliminate speed variance and linkage problems.

DC Electrical System

- DC system uses reliable relays instead of unrepairable printed circuit board.
- 12 volt starter motor and battery charging alternator with regulator and belt guard.
- Standard panel: Remote mount S-3C has hour and volt meters, oil pressure and coolant temperature gauges, stop-start switch and preheat switch.
- 20 foot (6 m) plug-in panel harness lets you mount your panel anywhere on board. DC system is expandable to six panels up to 110 feet from the set.
- Low oil pressure and high coolant temperature shutdowns are standard.



AC Generator

- Northern Lights, direct coupled, brushless AC generator is maintenance free. 12 lead design is reconnectable for 1 or 3 phase, 60 Hz output. Conservative heat rise rating: 95°C/50°C ambient.

- Automatic Voltage Regulator (AVR) is powered by dedicated AC winding for true 300% short circuit capability. Quick ±1% RMS no load to full load voltage regulation. AVR has circuit breaker protection.
- Generator features high quality Class "H" epoxy insulation, accessible diodes, over-sized bearing and junction box for wiring.

Special Equipment

- Rigid welded steel base frame.
- Four plateform mounts isolate vibration.
- Tough gray enamel paint for long life finish.
- Operator's and parts manuals standard.

Accessories and Optional Equipment

- Front power take off with 12 or 24V electric clutch and SAE B spline. At the touch of a button you can take up to 30 HP for your vessel's hydraulic system.
- Control panels with DC and AC gauges.
- 24 volt standard ground DC system
- Wire harness extensions and "Y" harness.
- Heat exchanger cooling with wet exhaust.
 - 2 inch wet exhaust muffler.
 - Exhaust / water separator.
- Dry exhaust: elbow, mufflers, 18" SS flex.
- Alarms and shutdowns for low oil level, low coolant level, raw water flow and overspeed.
- On board parts kits.
- Fuel filter-water separators.
- Shorepower switches.

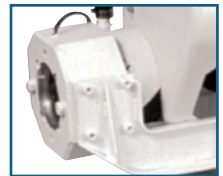

Dealer

4420 14th Ave. NW., Seattle WA 98107
Tel: (206) 789-3880 • 1-800-762-0165 • Fax: (206) 782-5455
Information and dimensions subject to change without notice.

Northern Lights and Lugger are registered trademarks of Northern Lights, Inc.

© 2011 All rights reserved. Litho USA. L714 03/11



www.northern-lights.com